

PASSENGER ADDRESS AND COCKPIT SPEAKER AMPLIFIER - REMOVAL/INSTALLATION**1. General**

- A. This section covers removal and installation procedures for the passenger address headphone amplifier and cockpit speaker amplifier.
- B. The passenger address headphone amplifier and cockpit speaker amplifier is located aft of the copilot position on lower fuselage at FS 175, underneath the right side cabin floor board.

2. Passenger Address Headphone And Cockpit Speaker Amplifier Removal/Installation

- A. Remove the passenger address headphone and cockpit speaker amplifiers (Refer to Figure 401).
 - (1) Remove external electrical power from the airplane.
 - (2) Disengage the AUDIO 1, AUDIO 2, PA AMP, PKR AMP and ICS circuit breakers.
 - (3) Get access to cabin floorboard panel cover. Reference Chapter 6, Access Plates And Panels Identification - Description And Operation.
 - (4) To get access to the amplifiers, remove the center cabin floorboard252AR.
 - (5) Disconnect the audio cable from the applicable amplifier.
 - (6) Remove the screws that attach the applicable unit to the mount.
 - (7) Carefully remove the applicable unit.
 - (8) Engage the AUDIO 1, AUDIO 2, PA AMP, SPKR AMP and ICS circuit breakers.
- B. Install the Passenger Address System and Cockpit Speaker Amplifier (Refer to Figure 401).
 - (1) Put the applicable amplifiers in its correct position.
 - (a) Install the screws that attach the amplifier to the mount.
 - (2) Connect the applicable audio cable.
 - (3) Install the center cabin floorboard.
 - (4) Install the cabin floorboard panel cover. Reference Chapter 6, Access Plates And Panels Identification - Description And Operation.
 - (5) Engage the AUDIO 1, AUDIO 2, PA AMP, SPKR AMP and ICS circuit breakers.

Figure 401 : Sheet 1 : Passenger Address and Cockpit Speaker Amplifier

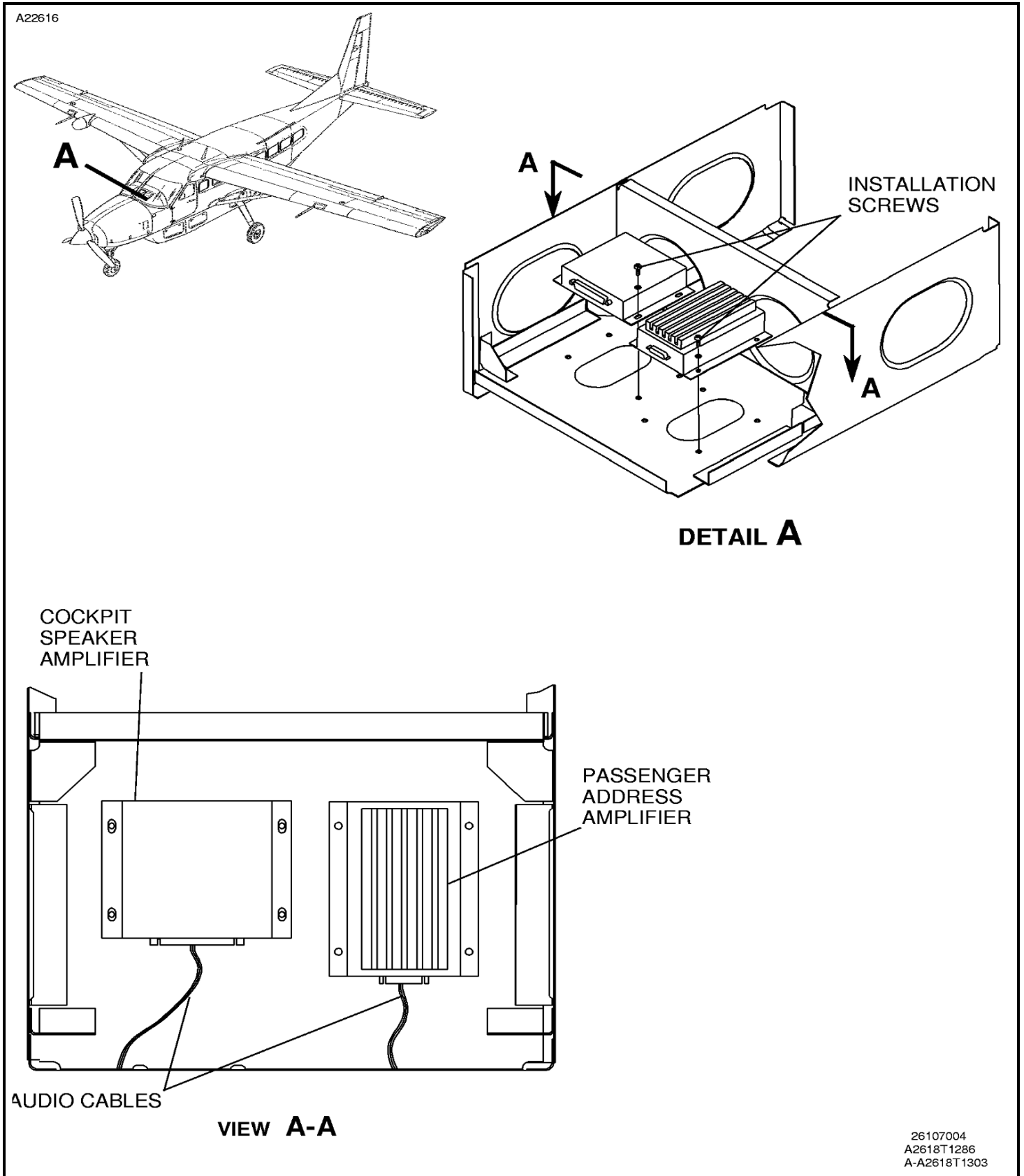

Figure 4 : Sheet 1 : Model 208B and 208B Super Cargomaster Panels

